



追求卓越 · 不斷創新
Pursuit of Excellence Incessant Innovation



勵德自動化有限公司
Leader Automation Co., Ltd.

勵德科技股份有限公司
Leader Technology Co., Ltd.



勵德自動化·專業信賴的團隊

Leader Automation, the specialist and trustworthy team.

公司簡介 Company profile

創立於民國77年，多年來以不斷研發創新的技術製造客製化產品，並重視服務品質，在業界已建立優良專業形象。

從事各種自動機械、電控系統設計規劃、圖面設計、現場組裝試車，舉凡PLC控制系統、PC控制系統、集合式網路架構系統、專業殺菌系統設計、線上量測系統(CCD、雷射、BARCODE)之設計開發、自動化系統整合等，擁有豐富的實務經驗。

近年來開始致力於工業用機械手臂之應用研發，可依客戶需求設計規劃，本公司擁有專業的服務水平與完整的機電整合技術，對於自動化設備研發、設計、製造都擁有專業的水準；生產之設備實用、耐用、價格合理及快速優質的售後服務，絕對是您最好的選擇。

勵德秉持「誠信、負責、創新、服務」，並以最高品質、創新研發客製化產品，符合顧客產業需求，不僅發揮精準運用，更能提升最大利潤。

Founded in April 1988, Leader Automation undertakes continual research and development for technology innovation to provide customers with comprehensive customization services. By putting service and quality first, we have established and earned a professional image in the business.

Specialized in the design and planning of various automation machinery and electrical control systems, drawing designs, and field assembly and commissioning, we have experience in the design, development, and integration of various automation control systems, including PLC control systems, PC control systems, integrated network systems, professional sterilization systems, on-line measurement systems (CCD, laser, barcode).

In recent years, we have been focusing on the research and development of robotic arm applications for customization. With professional services and complete electrical and mechanical integration know-how, we offer state-of-the-art research, development, design, and manufacture for practical, durable, and affordable automation equipment. Along with our fast and reliable after-sale service, Leader Automation will surely be your best choice.

Upholding “integrity, responsibility, innovation, and service”, we fulfill the needs of each customer with the best quality and innovative custom products through incessant research and development for customers to ensure precision and maximize profit.



獲獎&認證 Award & Certificate

勵德不斷精進的專業與技術，爲了讓產品與服務品質更好，除了技術研發外，也取得殺菌釜和機械手臂各項專利，並通過經濟部工業局技術服務登錄，專業獲國內外業界肯定。

Through continuous improvement of expertise and technology, Leader Automation aims to optimize product and service quality. In addition to technological research and development, we have been awarded patents for our Autoclave and Robot and passed the Technological Service Organization registration of the Industry Development Bureau (IDB) of the Ministry of Economic Affairs (MOEA).



經濟部工業局技術服務能量登錄證書
Certificate of Registration as a Technological Service Organization by IDB, MOEA



中小企業創新研究獎
Certificate of Taiwan small & medium enterprises innovation award



機械手臂EMC認證
Verification of EMC Compliance



機械手臂歐盟CE認證
EU CE certificate of competency



咖啡機器人歐盟CE認證
CE certificate for Robotic Coffee Shop

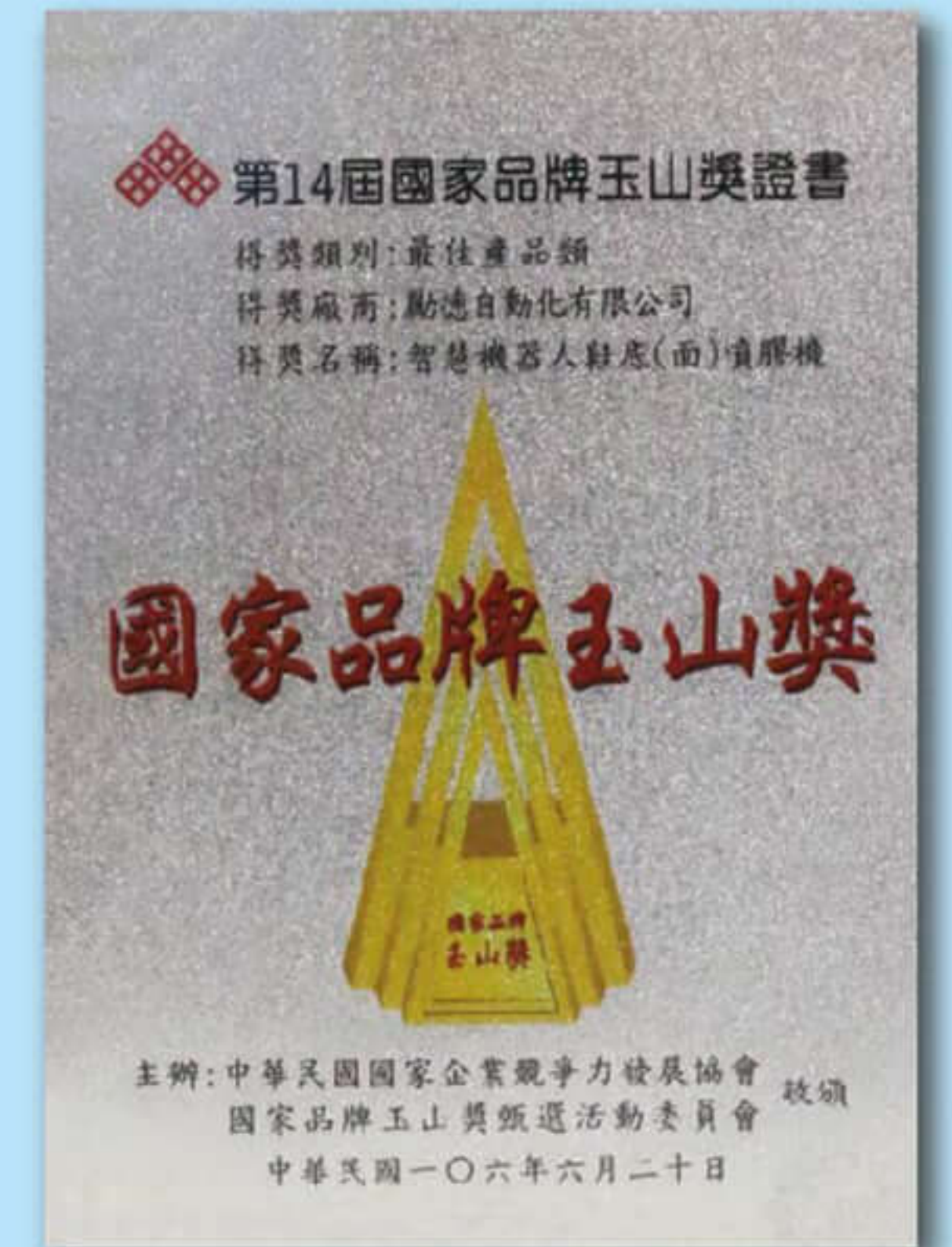

國家品牌玉山獎
The National Brand Yushan Award



咖啡機器人專利證書
ROC Certificate of Patent for Robotic Coffee Shop



咖啡機器人專利證書
PRC Certificate of Patent for Robotic Coffee Shop

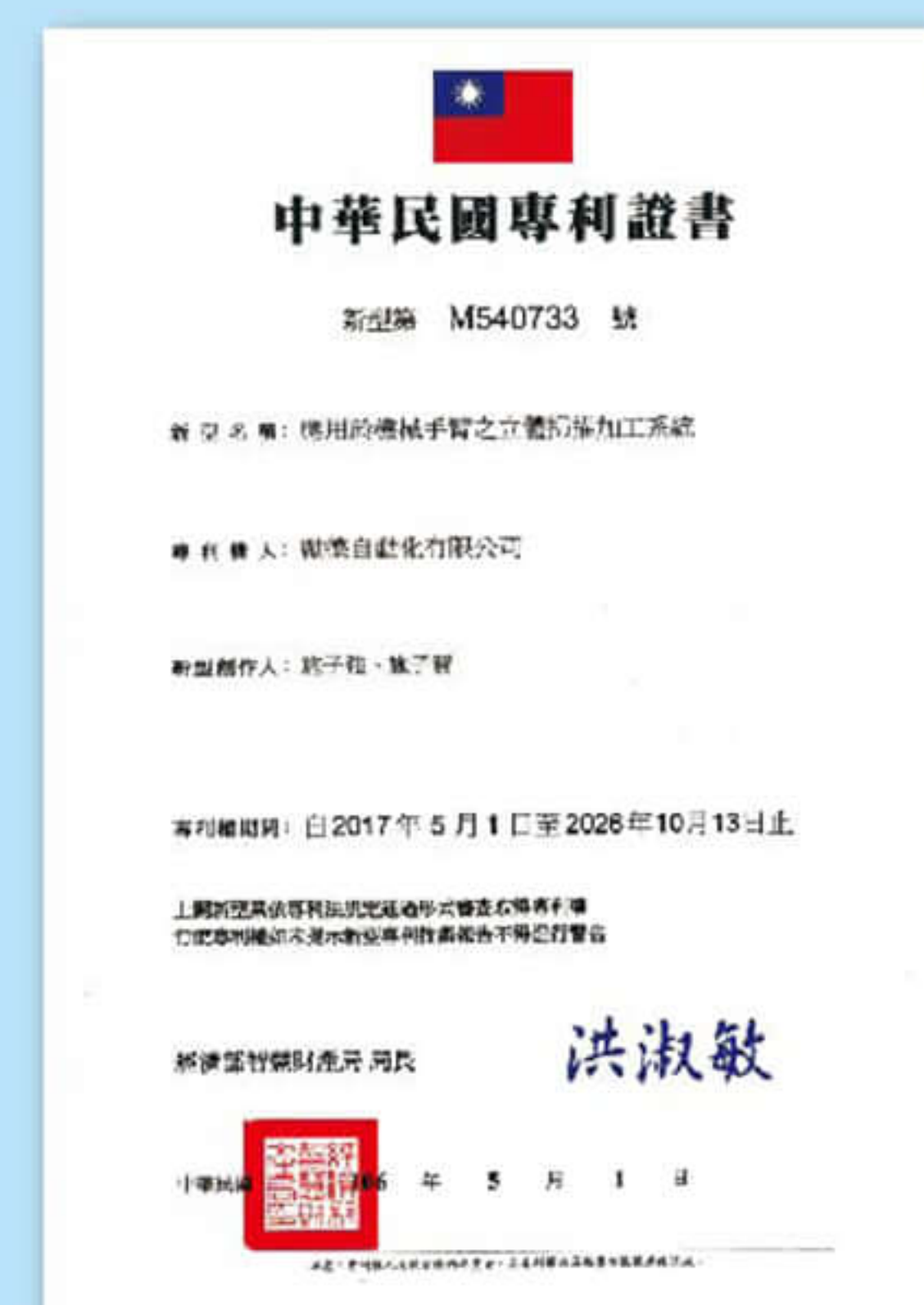

立體掃描加工系統專利證書
ROC Certificate of Patent for Dimensional scanning processing system



機械手臂果凍雕花發明專利
ROC Patent for Robotic Integration of 3D Jelly Flower

LD2-R620 六軸關節型機械手臂

6-axis articulated robot



● 動作範圍 Workable Space

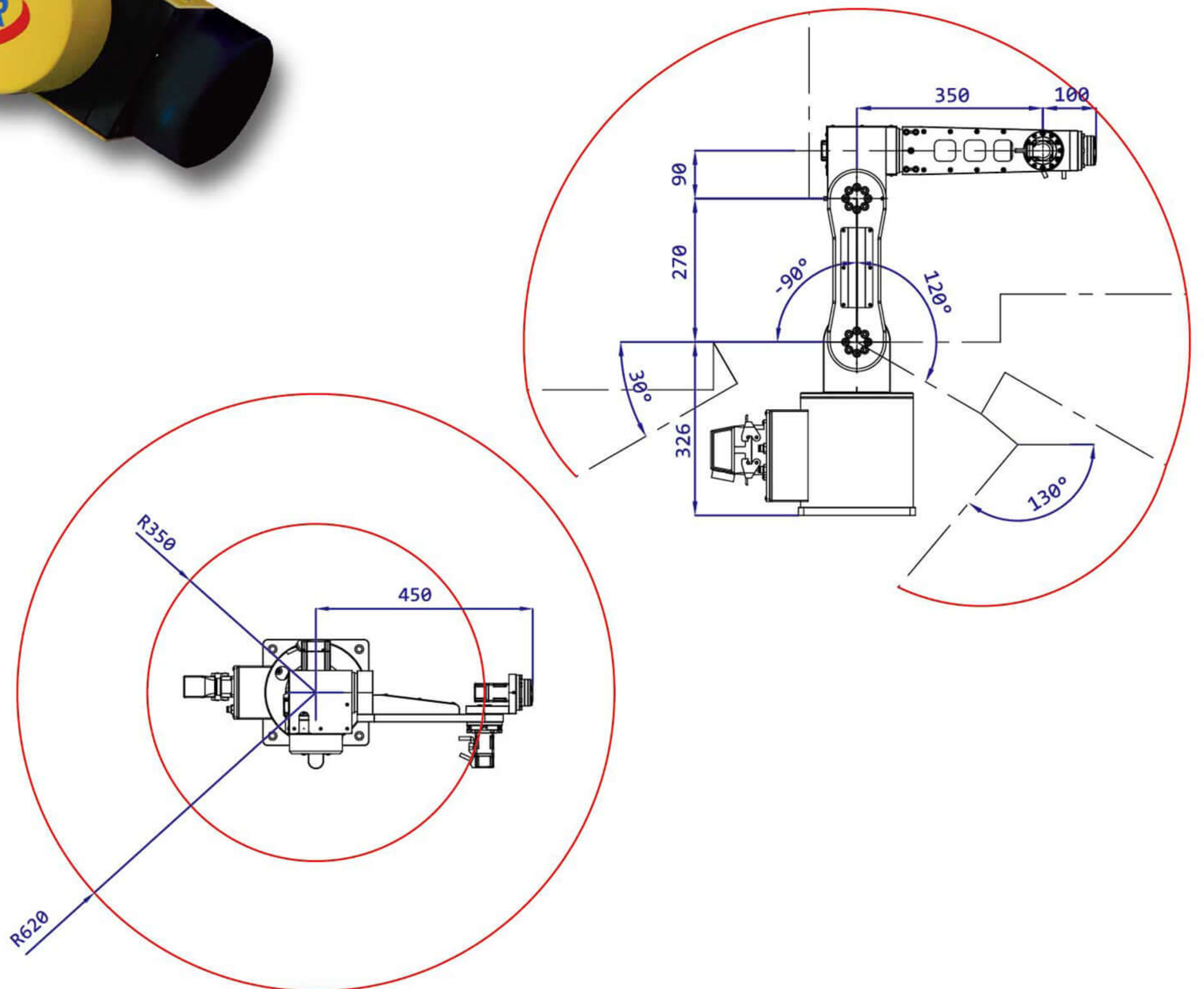

自由度 Controlled Axis	6	
最大負載 Maximum Payload	2 kg	
P 點最大可達半徑 P-point Reach (max.)	620 mm	
運動範圍 Motion Range	J1	360° (+180°~ -180°)
	J2	210° (+120°~ -90°)
	J3	340° (+210°~ -130°)
	J4	360° (+180°~ -180°)
	J5	240° (+120°~ -120°)
	J6	720° (+360°~ -360°)
重覆定位精度 Position Repeatability	In each of X ,Y and Z directions: ±0.03mm	
重量 Weight	Approx. 50 kg	
安裝方式 Installation	地面安裝 Floor	
軌跡教導 Trajectory Teaching	手持盒教導 Teaching Box 順應牽引教導 Compliance Teaching	

LD7-R700 六軸關節型機械手臂 6-axis articulated robot



● 動作範圍 Workable Space

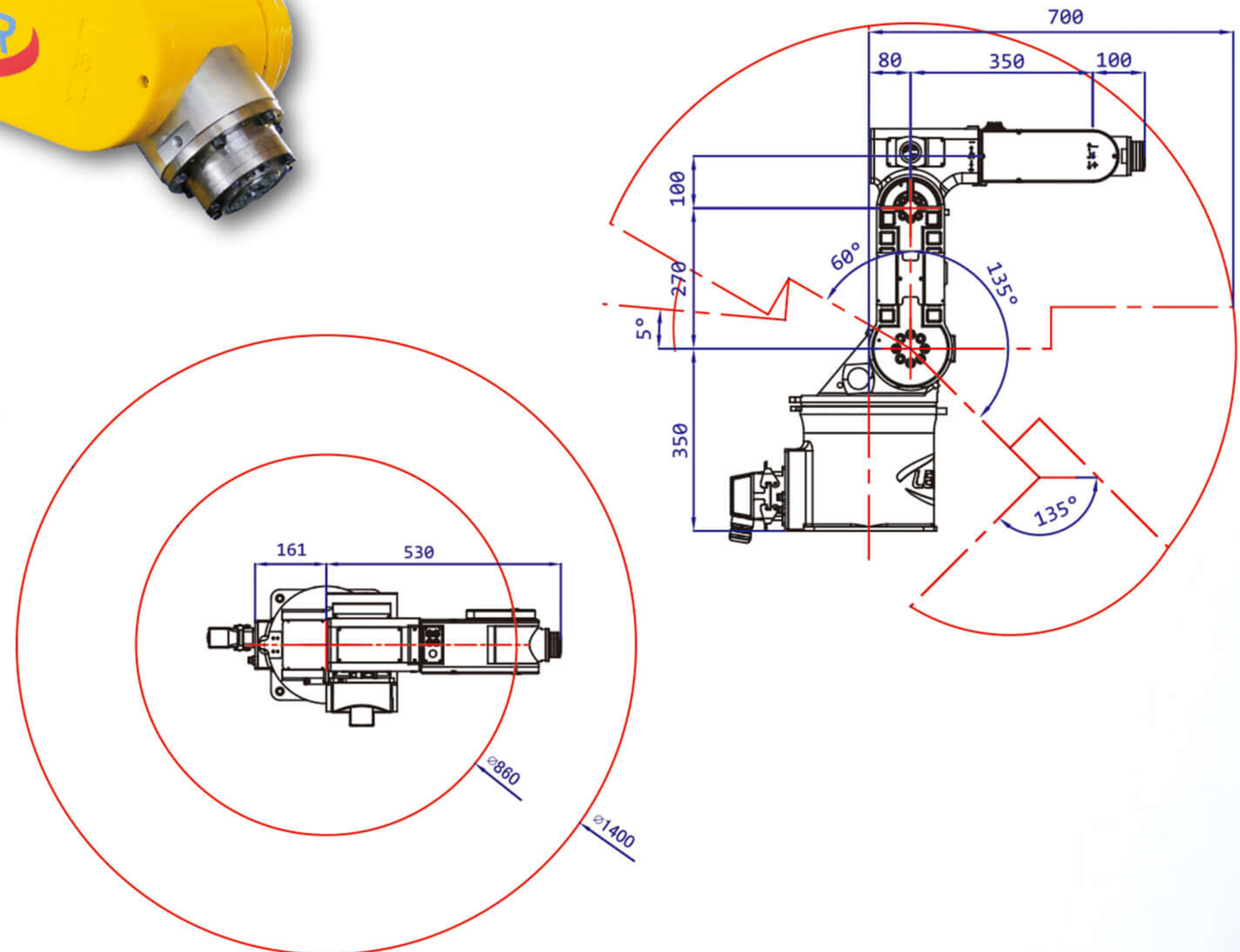

自由度 Controlled Axis	6	
最大負載 Maximum Payload	7 kg	
P 點最大可達半徑 P-point Reach (max.)	700 mm	
運動範圍 Motion Range	J1	360° (+180°~ -180°)
	J2	195° (+135°~ -60°)
	J3	210° (+170°~ -40°)
	J4	360° (+180°~ -180°)
	J5	200° (+100°~ -100°)
	J6	720° (+360°~ -360°)
重覆定位精度 Position Repeatability	In each of X ,Y and Z directions: ±0.04mm	
重量 Weight	Approx. 49 kg	
安裝方式 Installation	地面安裝 Floor	
軌跡教導 Trajectory Teaching	手持盒教導 Teaching Box 順應牽引教導 Compliance Teaching	

LD10-R1400 六軸關節型機械手臂

6-axis articulated robot



● 動作範圍 Workable Space

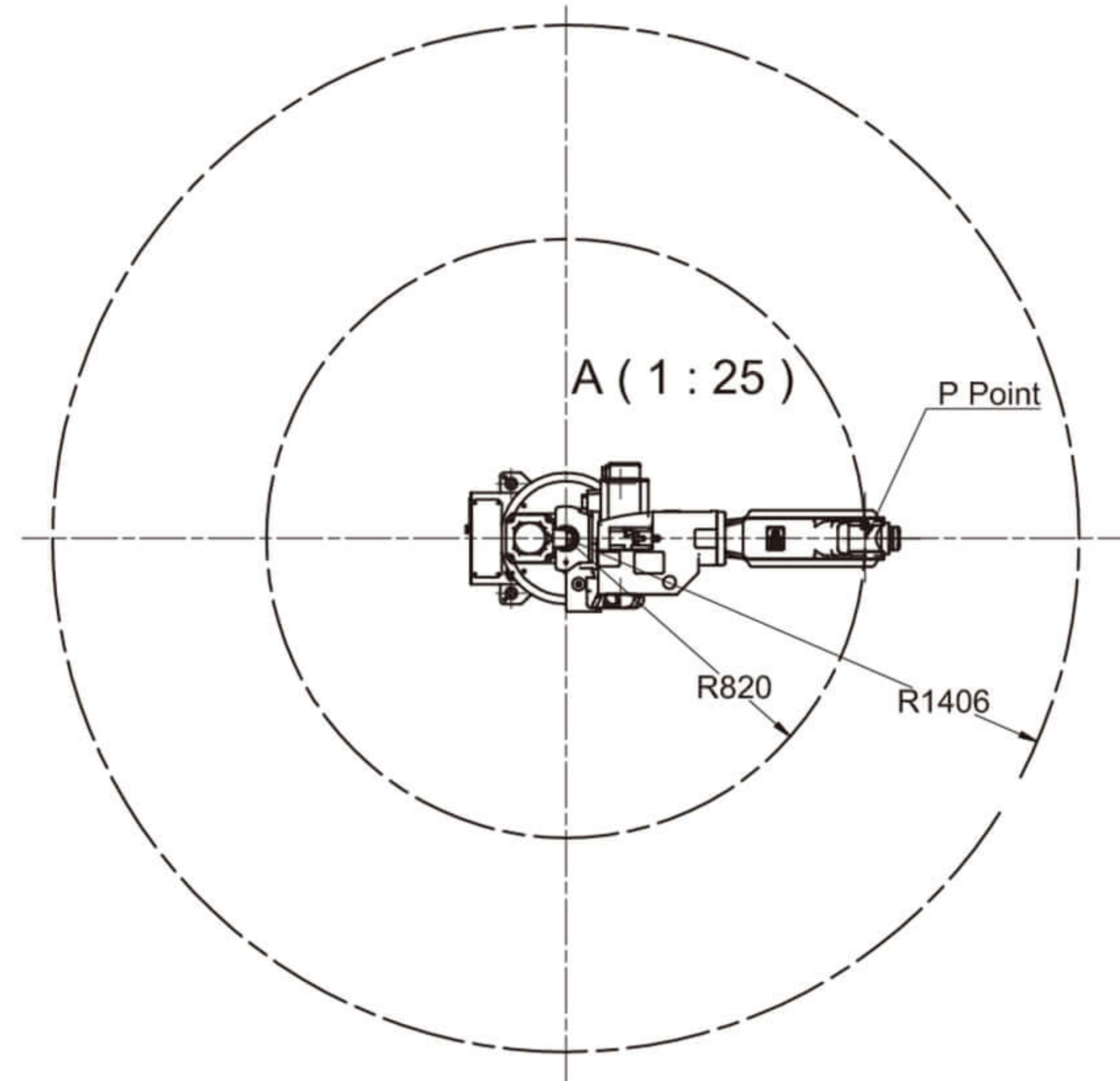

4- \varnothing 17.5 THRU
 \perp \varnothing 32 ∇ 2mm (背面)

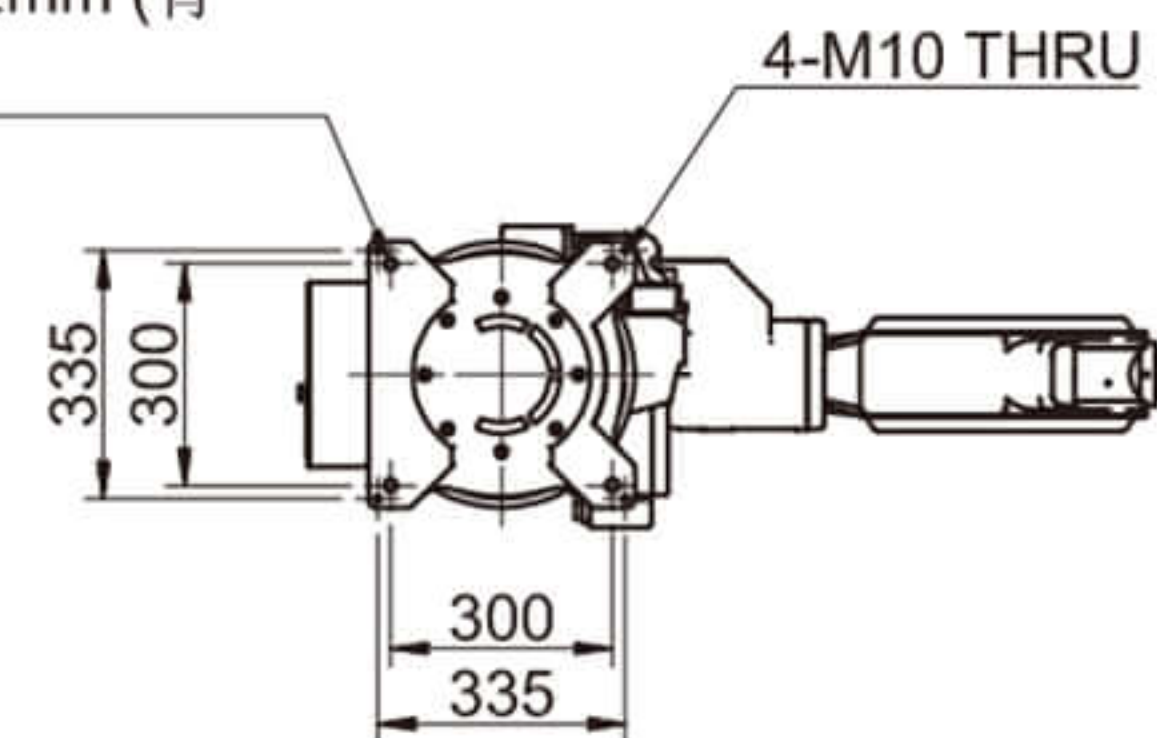

B (1:5)

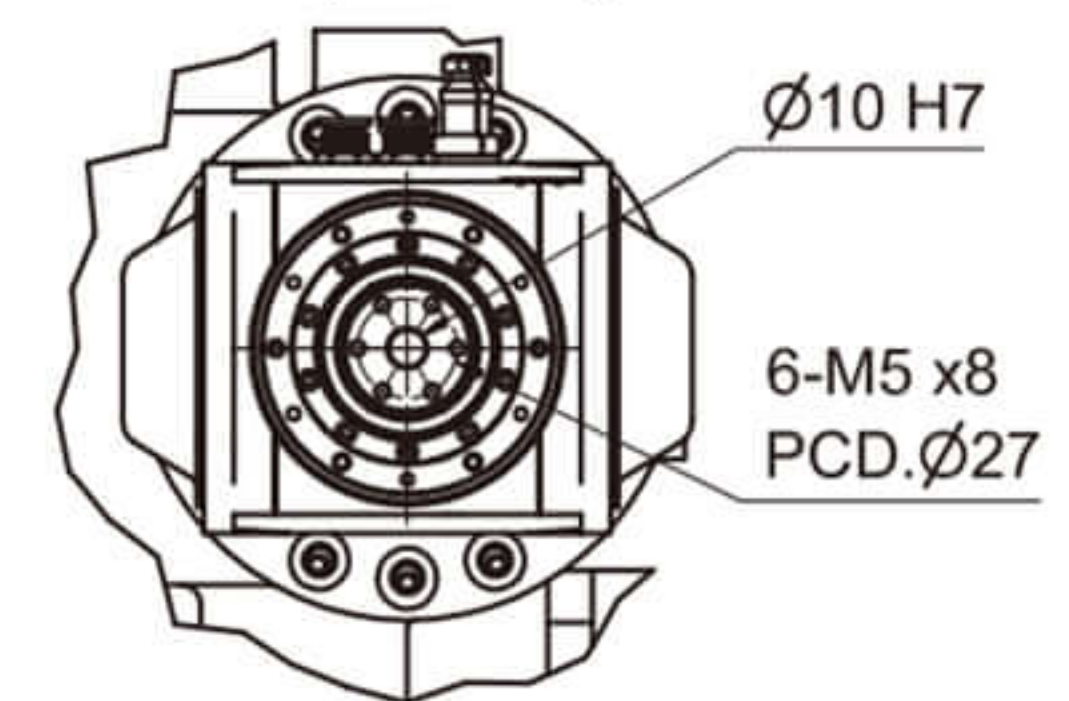

自由度 Controlled Axis	6	
最大負載 Maximum Payload	12 kg	
P 點最大可達半徑 P-point Reach (max.)	1,400 mm	
運動範圍 Motion Range	J1	340° (+170° to -170°)
	J2	245° (+155° to -90°)
	J3	190° (+170° to -20°)
	J4	360° (+180° to -180°)
	J5	280° (+140° to -140°)
	J6	720° (+360° to -360°)
重覆定位精度 Position Repeatability	In each of X, Y and Z directions: ± 0.06 mm	
重量 Weight	Approx. 163 kg	
安裝方式 Installation	地面安裝 Floor	
軌跡教導 Trajectory Teaching	手持盒教導 Teaching Box	

LD20-R1660 六軸關節型機械手臂 6-axis articulated robot



● 動作範圍 Workable Space

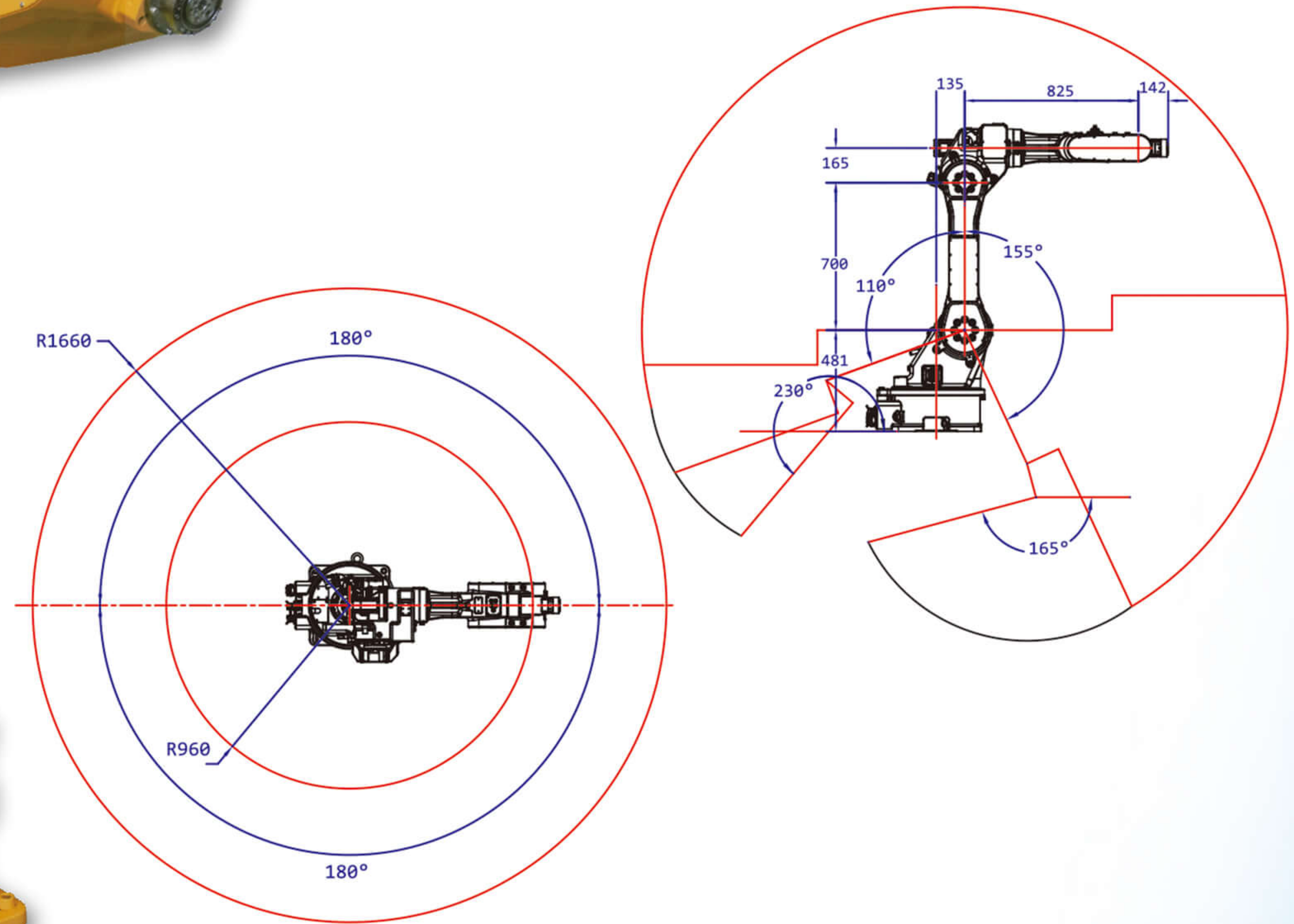

自由度 Controlled Axis	6	
最大負載 Maximum Payload	20 kg	
P 點最大可達半徑 P-point Reach (max.)	1660 mm	
運動範圍 Motion Range	J1	360° (+180°~ -180°)
	J2	265° (+155°~ -110°)
	J3	395° (+165°~ -230°)
	J4	360° (+180°~ -180°)
	J5	260° (+130°~ -130°)
	J6	720° (+360°~ -360°)
重覆定位精度 Position Repeatability	In each of X, Y and Z directions: ±0.1mm	
重量 Weight	Approx. 300 kg	
安裝方式 Installation	地面安裝 Floor	
軌跡教導 Trajectory Teaching	手持盒教導 Teaching Box	

智慧機器人鞋底噴膠機

Intelligent Robot Outsole Glue Spraying System

產品介紹 Product profile

功能

- (一) 高解析度3D掃描、擷取物件細度特徵、輪廓及邊緣高精度之密度資料。
- (二) 3D輪廓密度資料，經電腦演算及優化轉換為X、Y、Z座標，提供Robot功能目的運行。
- (三) 提供 Robot 運行軌跡、執行速度、傾斜角度等多種參數改變功能。

用途

- (一) 適用於以X、Y、Z為運行軌跡之各型機械手臂。
- (二) 適用產業如鞋業鞋底噴膠、皮革業黏著面噴膠。
- (三) 汽車業擋風玻璃塗膠貼合、3C產業塗膠貼合。

工業4.0技術及特色

- (一) 智慧3D掃描系統可判讀範圍內任意擺放之物件、形狀密度資料。
- (二) 透過物聯網系統架構，3D掃描資訊即刻演算、交換傳遞軌跡至Robot執行。
- (三) 具自動化產線整合方便性。

Functions

1. High-resolution 3D scanning for capturing the details of object features and high precision density data of contour and edges.
2. 3D contour density data is converted into X, Y, and Z coordinates through computer calculation and optimization for the robot to run according to the set target.
3. Support adjustment of various parameters, including robot trajectory, running speed, angularity, and so on.

Application

1. Suitable for use on all kinds of robotic arms with X, Y, Z trajectories.
2. Suitable for use in outsole glue spraying and leather spraying.
3. windshield adhesive coating and bonding for the auto industry, and adhesive dispensing and bonding of 3C industries.

Industry 4.0 and features

1. This intelligent 3D scanning system can read the density data of any objects and shapes within the scan range.
2. By connecting to the IoT, 3D scan information can be calculated, converted into trajectory data, and transmitted to the robot for execution simultaneously.
3. Support integration with automated production lines.

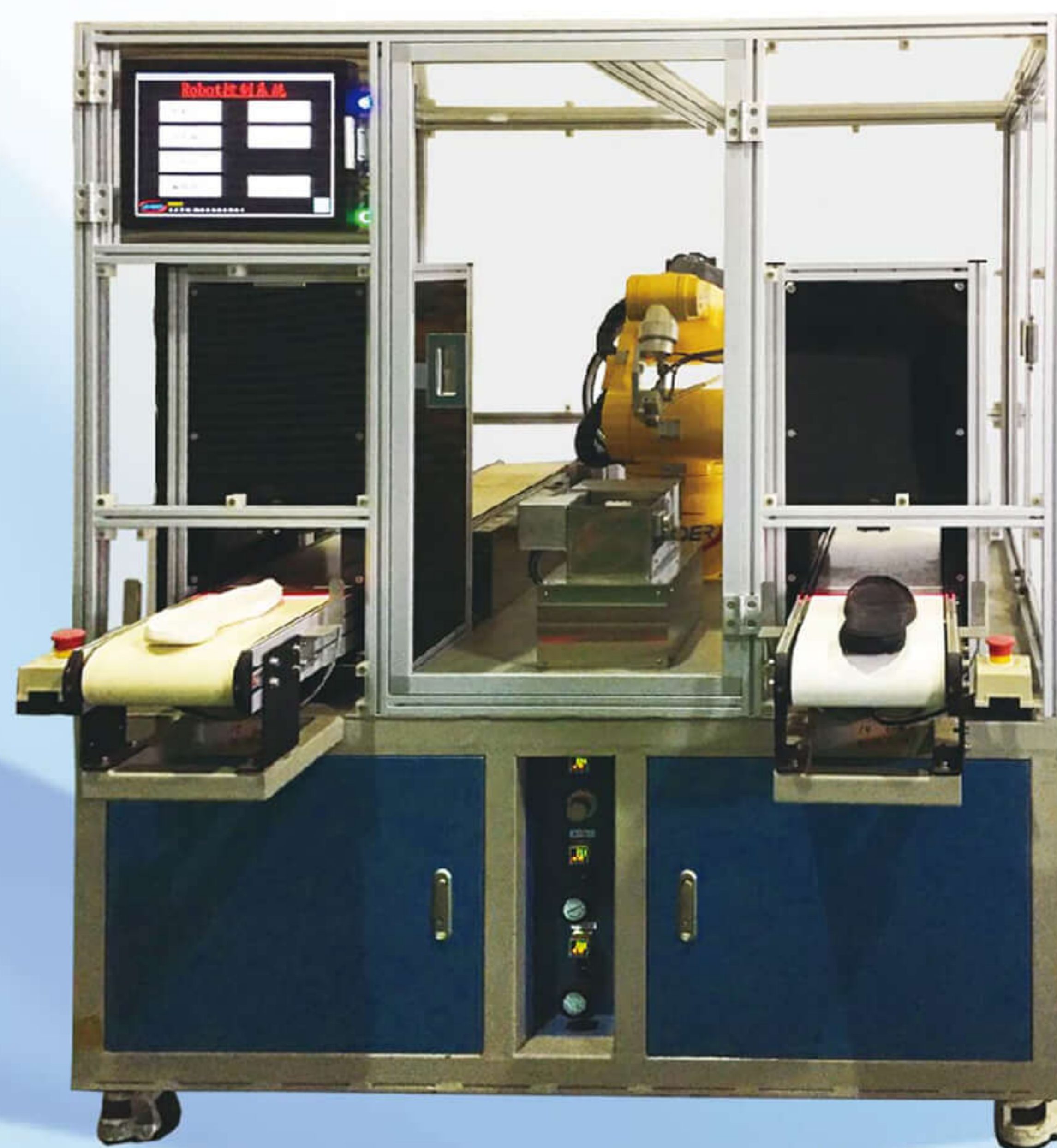
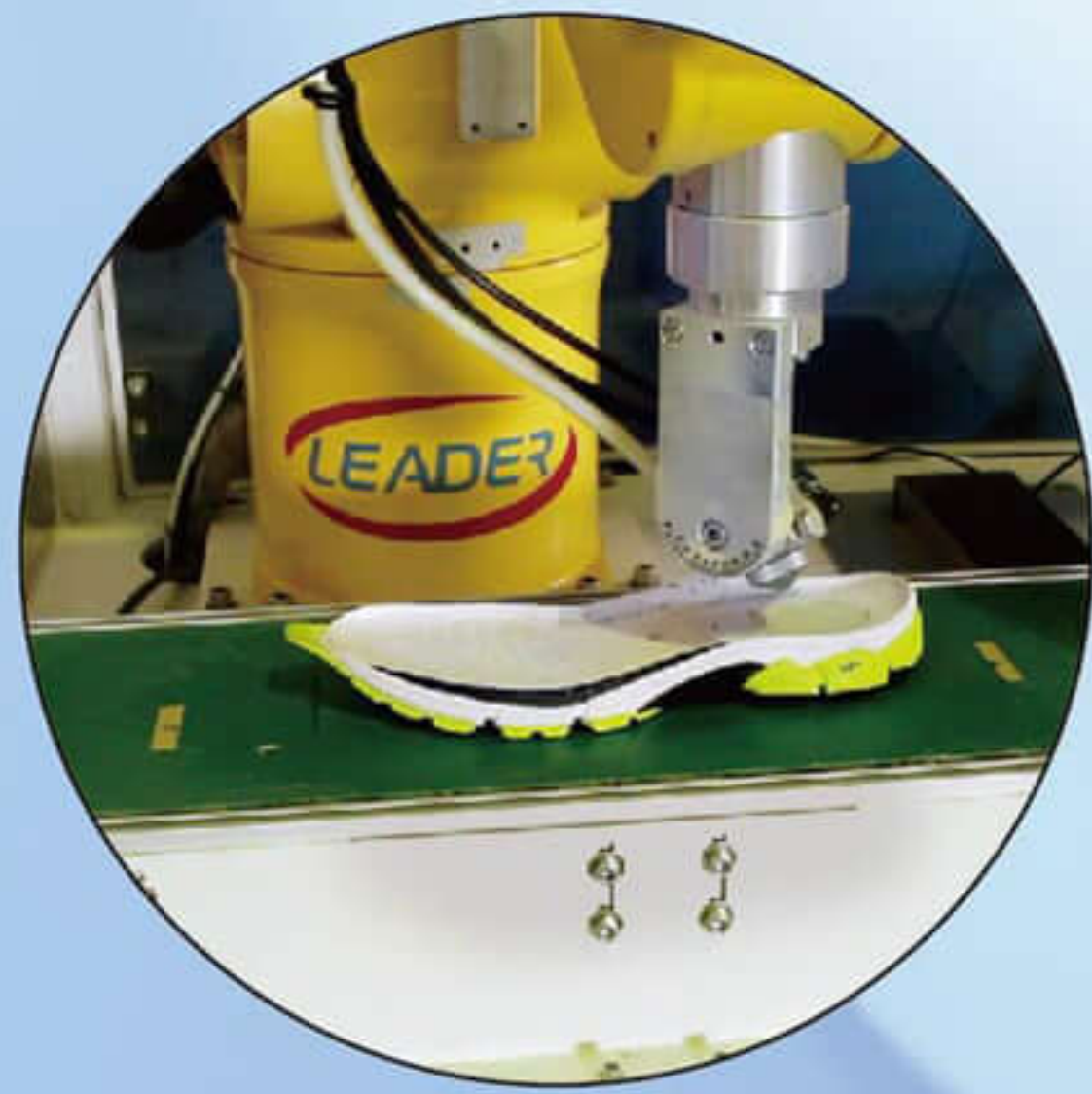

3D掃描原始檔
3D scan original file

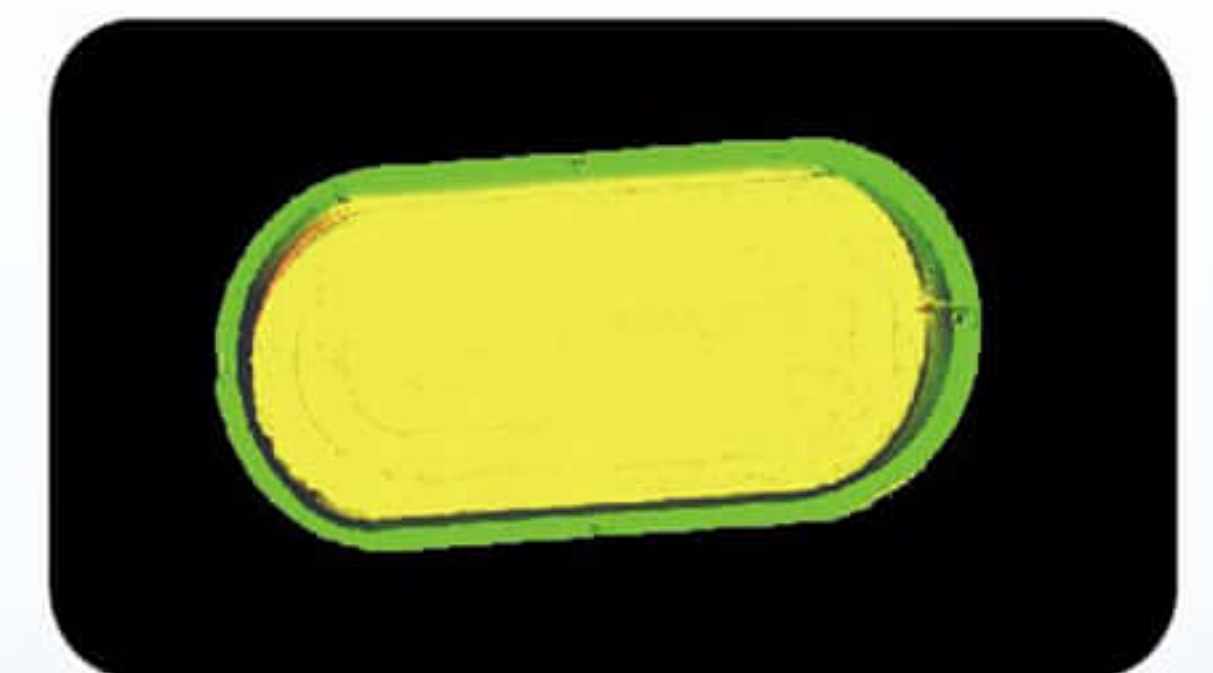
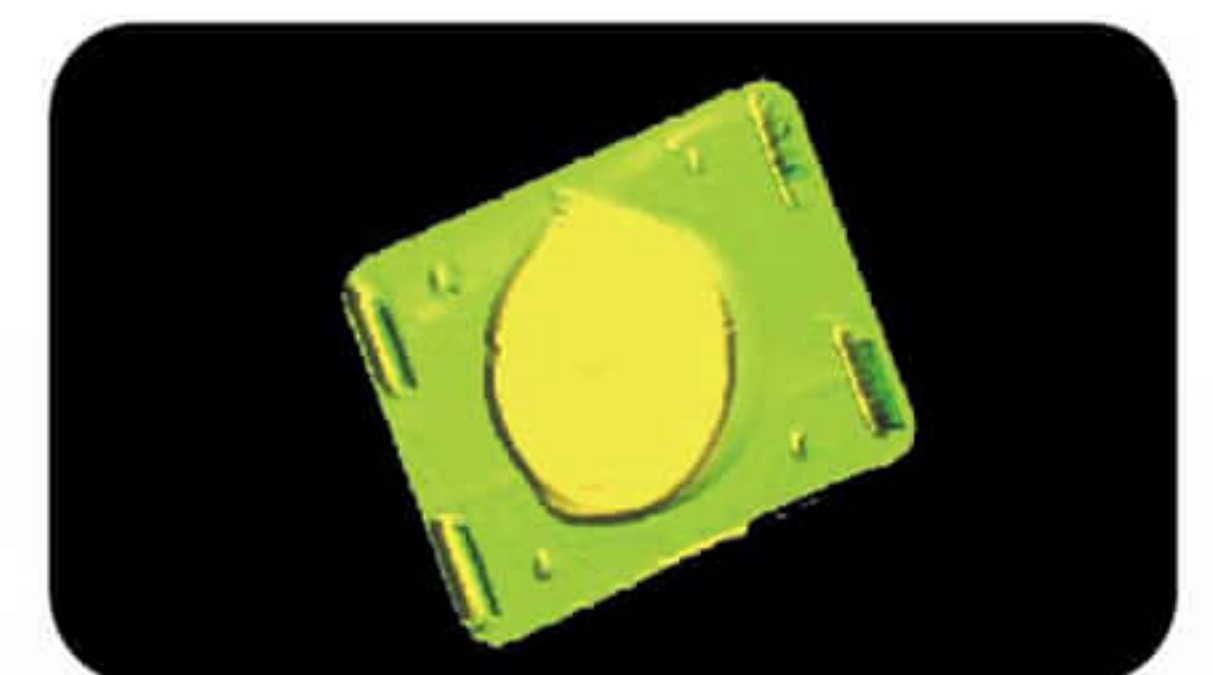

· 掃描軌跡優化 (X, Y, Z座標) Trajectory optimization (X, Y, Z coordinate)

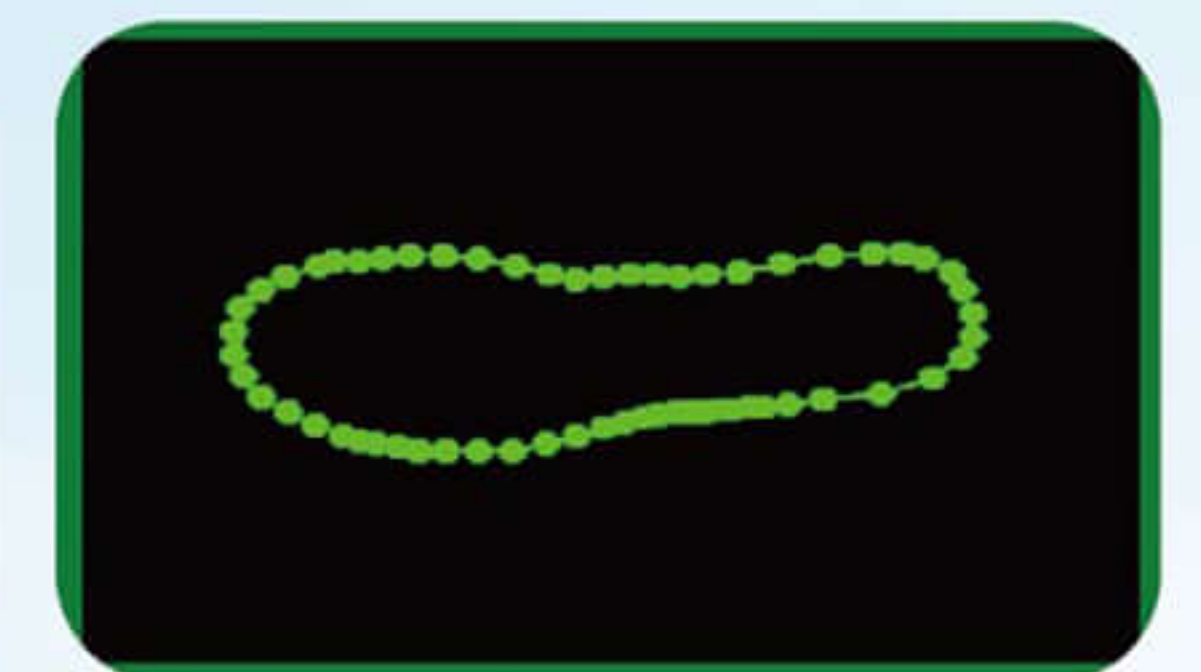
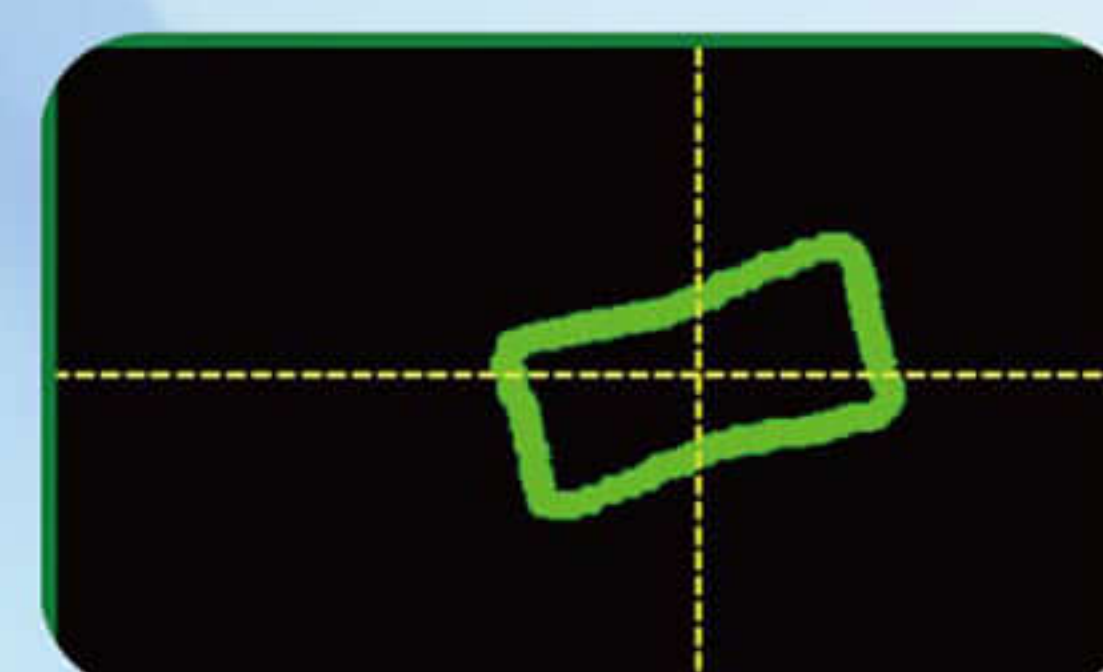
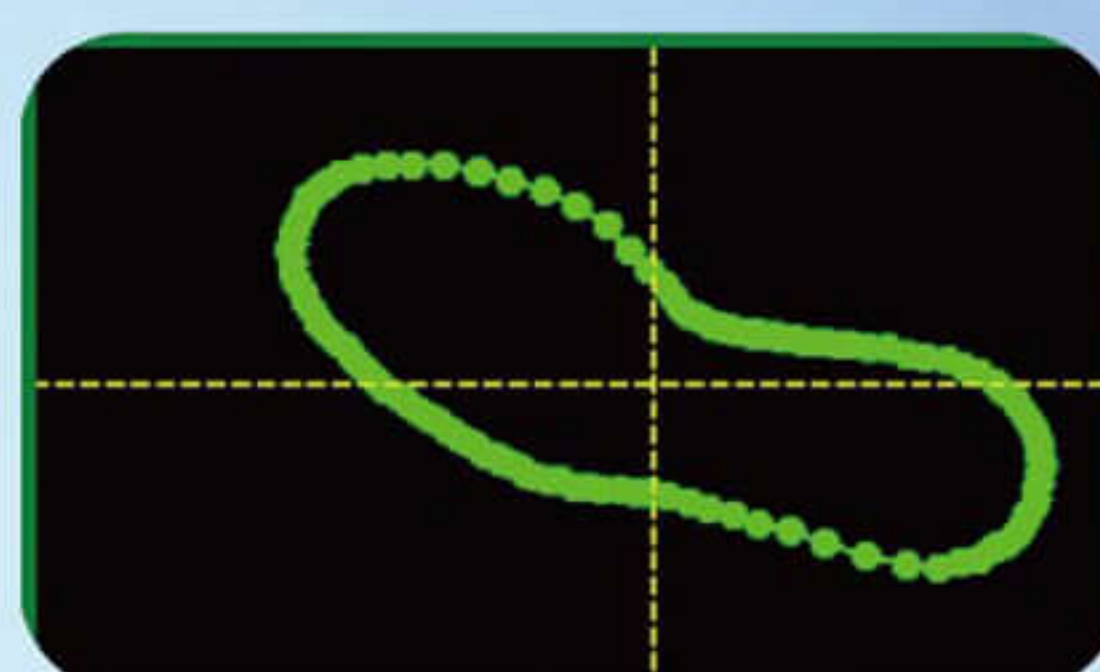
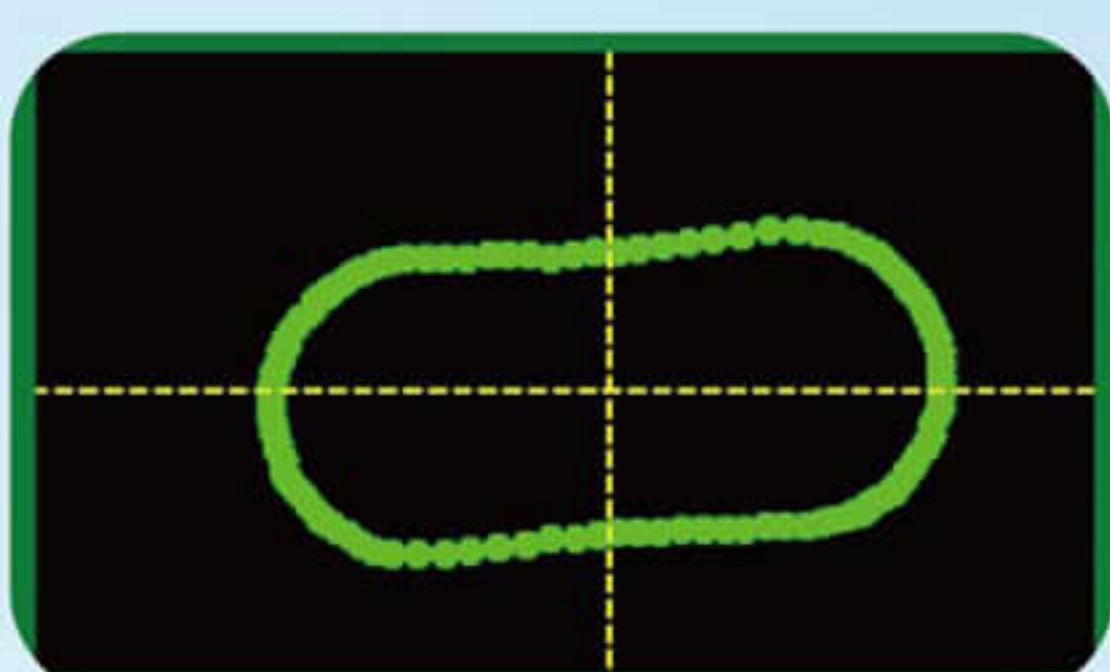
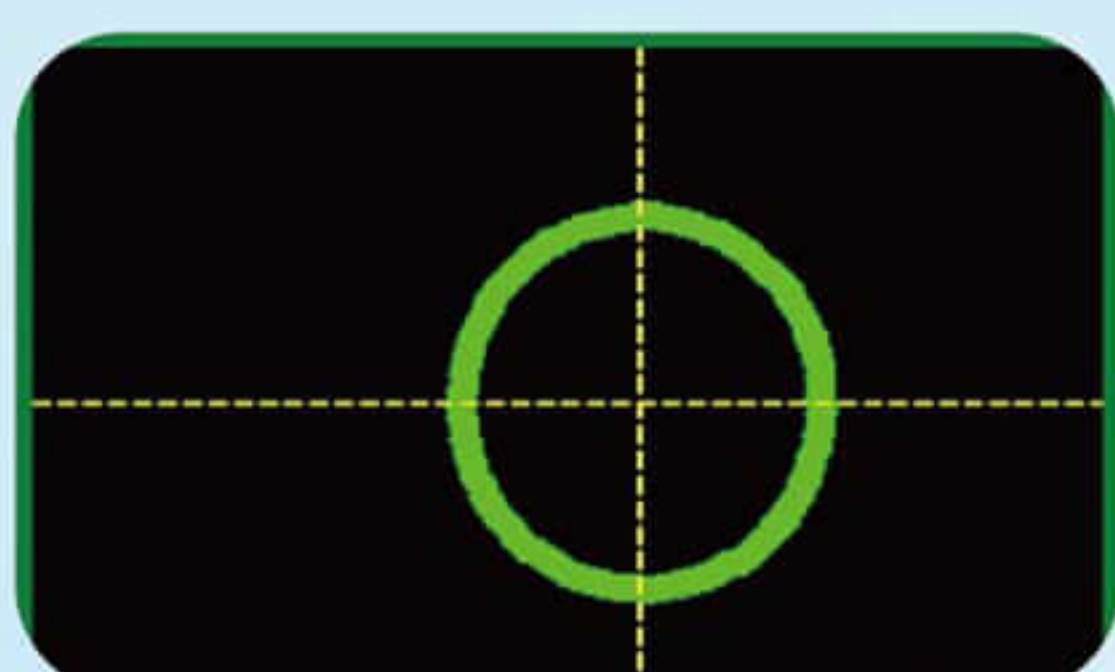

3D 果凍雕花機

Robot integration of 3D Jelly Flower

產品介紹 Product profile

功能

勵德公司已將藝術家的巧手，包含非常細膩柔軟的手指繞曲動作，完整經由Robot模擬體現出來。透過視窗介面操作便可進行各種花型編輯，包含花瓣數量、花瓣層數及傾斜角度等，設定完成，Robot同時整合周邊設備系統，馬上精確執行立體雕花，達到3D果凍雕花製作。

特色

- (1) 簡易介面化操作可編輯各種花型。
- (2) 自動化整合周邊設備包含注膠與旋轉盤。
- (3) 六軸機械手臂精準執行雕花路徑。
- (4) 食材配方教導。

說明

世界唯一國內首創自行開發「Robot整合3D果凍雕花」其速度是人工3至5倍，提高工作效率、提升產值及利潤、穩定執行降低不良率。

勵德公司提供專屬客製化服務，讓您掌握獨創性。 **■ 獲得發明專利 ■**

Function

Leader Automation has successfully simulated the delicate and agile finger motions of artist through robots. From the graphic user interface, users can edit all kinds of flower patterns, including the number of pedals, the number of pedal layers, and their inclined angles. After setup, the robot will integrate peripheral systems to immediately and accurately start carving until the finish of the 3D jelly flower.

Features

1. Easy and simple to operate interface for editing all kinds of flower patterns.
2. Automated integration of peripheral equip-ment, including dispenser and rotary table.
3. Six-axis articulated robot for precision carving.
4. Food ingredient teaching

Description

The world's only and Taiwan's first independently developed robot integration of 3D Jelly Flower. Three to five times faster than manual carving enhances work efficiency; increases value and profit, and improve work stability to reduce defect rate. Exclusive customization service from Leader Automation for you to create uniqueness. **■ Awarded Invention Patent ■**



智能化無人茶飲店 Robotic Bubble Tea Shop

功能：

自動執行飲料之茶品充填、加糖、加冰、加珍珠粉圓、貼標等工作，能快速完成、節省時間，並減少不良率，穩定飲料的品質。「智能化無人茶飲店」不僅提供完整的後台製作流程，也整合前台智慧點餐系統，進一步提升點餐速度與品質。**[獲得專利權]**

Automatically perform the tea filling, sugar, ice, bubble, labeling and other tasks of the beverage, which can be completed quickly, save time, reduce the defect rate, and stabilize the quality of the beverage. The "Robotic Bubble Tea Shop" not only provides a complete back-end production process, but also integrates the front-end intelligent ordering system to further improve the speed and quality of ordering. **[Awarded Utility Patent]**

特色：

- (1)智慧點餐機提供飲料的選擇以及付款(含投幣、紙鈔、行動支付、發票、QRcode領取單)。
 - (2)自動化整合周邊設備包含自動落杯、珍珠充填、製冰機、果糖機、果汁機、飲料充填、封膜機、標籤列印等。
 - (3)一次可連續製作9杯。
 - (4)各飲料可選擇需要的糖量、冰量以及是否要加珍珠。
 - (5)缺料或故障即時通知：支援Line、維信、簡訊、Email方式，可即時及定時發訊息通知業者機台狀況以及是否需要補料。
 - (6)後台管理系統：每日消費統計記錄（品項、數量、金額、時間），並可匯出Excel檔案。
 - (7)具備API通訊功能，可與POS系統串接。
- (1)Intelligent ordering system provides beverage selection and payment (including coin, cash, mobile payment, invoice, QRcode receipt)
 - (2)Automatic integration of peripheral equipment including automatic cup supplier, bubble supplier, ice maker, fructose machine, juicemachine, beverage filling, film sealing machine, label printing, etc.
 - (3)Can make 9 cups continuously at a time
 - (4)Each beverage can choose the amount of sugar, ice, and whether to add bubble
 - (5)Real-time information will be sent if there is any material shortage or malfunction: supporting Line, WeChat, text message or email, where the information regarding machine status can be sent to the vendors in real time or periodically
 - (6)Backstage management system calculates all the records of consumption everyday (item, quantity, amount and time) and exports them to Excel file
 - (7)With API communication function, can be connected with POS system

















勵德自動化·專業信賴的團隊

Leader Automation, the specialist and trustworthy team.

產品系列 Products

工業用機械手臂 Industrial Robots	食品、藥品殺菌系統 Food and Drug Sterilization Systems	客製化自動化設備 Custom Automation Equipment	精密線上量測設備 Precision On-line Measurement Equipment
電力監測系統 Power Monitoring System	電梯控制、快速換模系統 Elevator Control and Quick Mold Replacement System	工業4.0技術研發 Industry 4.0	自動光學檢測 AOI

專業 · 誠信 · 高效率 Expertise · Integrity · Efficiency

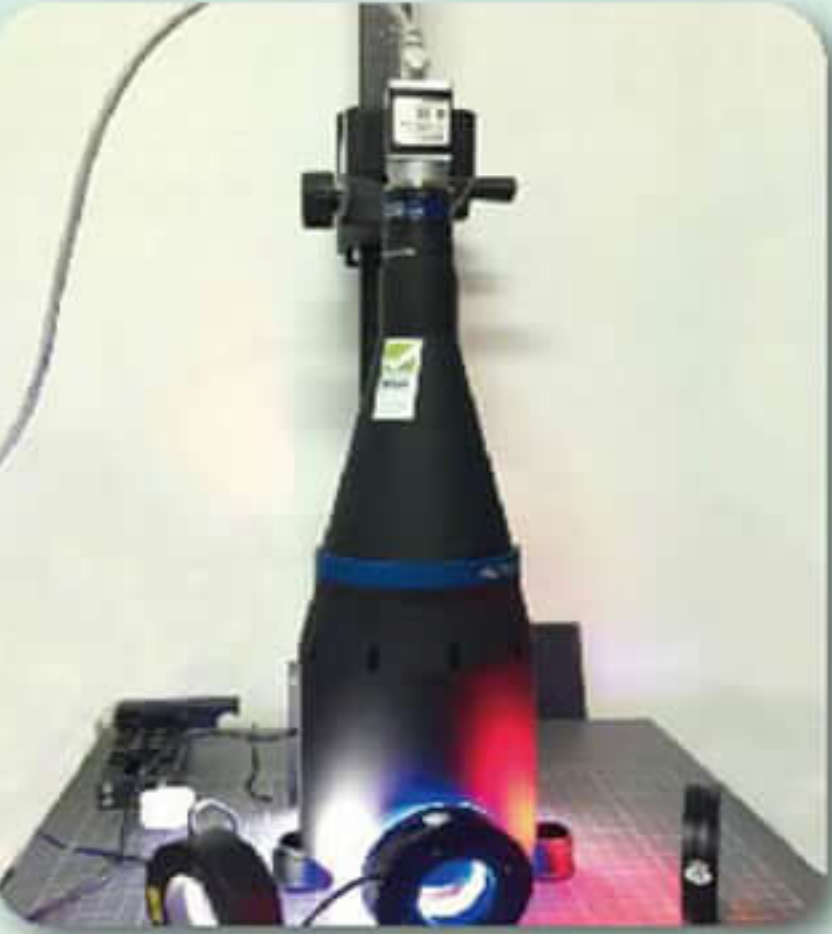
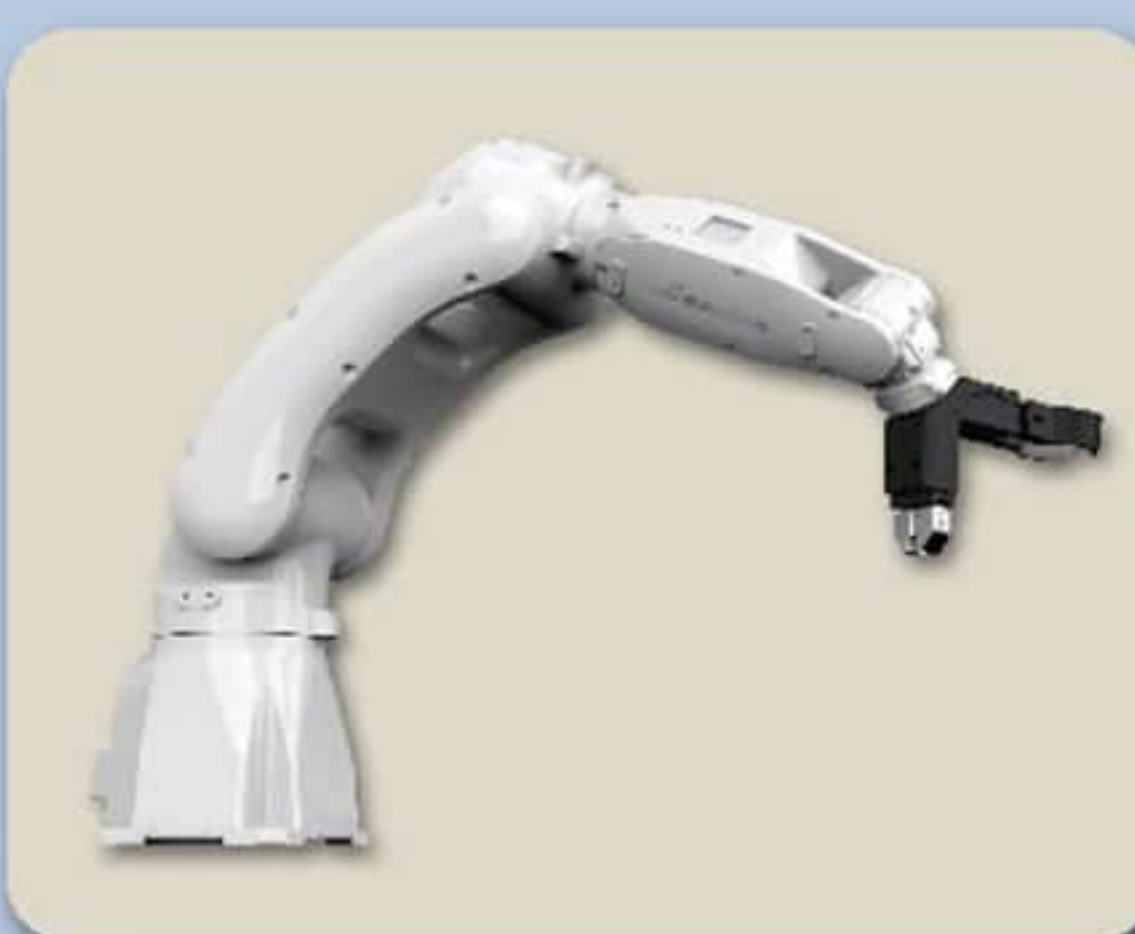
 <p>油壓沖床應用 Hydraulic punching machine</p>	 <p>射出機應用 Injection molding machine</p>	 <p>無人工作站手臂應用 Automation workstation</p>	 <p>沖床應用 Mechanica press</p>
 <p>水淋式全自動高溫殺菌設備 Sprinkle water auto Autoclave</p>	 <p>行走軸結合棧板堆疊系統 Robot Linear Axis combined with Paletizing</p>	 <p>棧板推疊應用 Paletizing</p>	 <p>智慧機器人自動切蛋糕機 Intelligent Robotic Cake Cutting Machine</p>
 <p>各式試驗機控制系統 All kinds of tester control System</p>	 <p>震動盤結合影像辨識 Image recognition system combined with Vibrator Bowl</p>	 <p>智慧機器人自動咖啡販賣機 Robotic Coffee Shop</p>	 <p>電力監控系統 Power Monitoring System</p>
 <p>線上量測系統 On-line measurement system</p>	 <p>工業4.0聯網自動充填系統 Industry 4.0 / auto filling system</p>	 <p>自動光學檢測 Automatic Optical Inspection (AOI)</p>	 <p>機器人應用系統(UR、安川手臂) Robotic Application System (UR、YASKAWA)</p>



勵德自動化有限公司 | 勵德科技股份有限公司
Leader Automation Co., Ltd. | Leader Technology Co., Ltd.

51542 彰化縣大村鄉中山路3段2巷430號
No. 430, Lane 2, Section 3, Zhongshan Road,
Dacun Township, Changhua County, Taiwan 51542
TEL : 886-4-8524640 | FAX : 886-4-8526341
E-mail : ldauto@ld-auto.com | <http://www.ld-auto.com>